



AUSTRALIA'S

National Association of **Forest Industries**

Timber Tips

Harry & Sal's Dog House

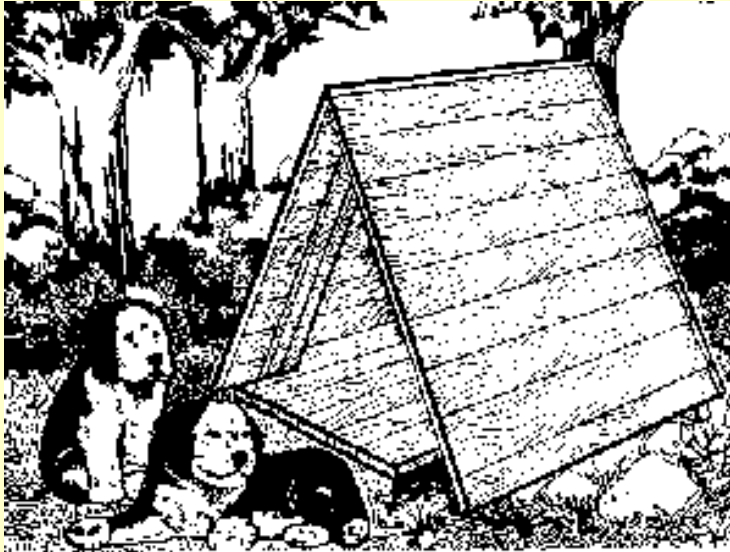

A roof over the head of that four legged family friend is often neglected. Sun, rain, wind and snow can make their life uncomfortable. But here is a design for a simple A-Frame shelter which is easy to put together and could be adapted for all sizes of dogs.

While the method of building this kennel is suitable for all sizes, the measurements given would be satisfactory only for a medium sized dog about 400 mm high.

If you wish to adjust the size to suit your dog, remember that the dog should not

only be able to stand upright inside the kennel but should also be able to turn around before he/she curls up and lies down.

TOOLS YOU WILL NEED	MATERIALS YOU WILL NEED	
<ul style="list-style-type: none"> • Hammer • Saws • Measuring tape/rule • Carpenter's square and pencil • Adjustable spanner • Drill and bits • 60o/30o set square 	<p>TIMBER (For example only)</p> <p>75 x 50mm, 6 pieces 1.2m* for two A-Frames (use durable timber)</p> <p>75 x 25mm, Decking, or equivalents, 16 pieces</p> <p>1.2m* (for flooring)</p> <p>Scandinavian Pine Cladding* in 1.2m lengths (22 lengths should be sufficient for</p>	<p>HARDWARE</p> <p>4/125 x 9mm Galvanise cup head bolts, nuts, washers.</p> <p>100/50 x 2.8mm Galvanised flat head nails.</p> <p>75 x 75mm x 1.2m length of zincalume angle as ridge capping OR 1.2m length of aluminium dampcourse.</p>

overall height of wall/
roof and the end walls).

*Consult your TABMA
merchant for suitable
available materials and
how these can be
ordered.

12/12 x 3.2m
Galvanised round head,
metal thread, screws.

Features of the Dog House

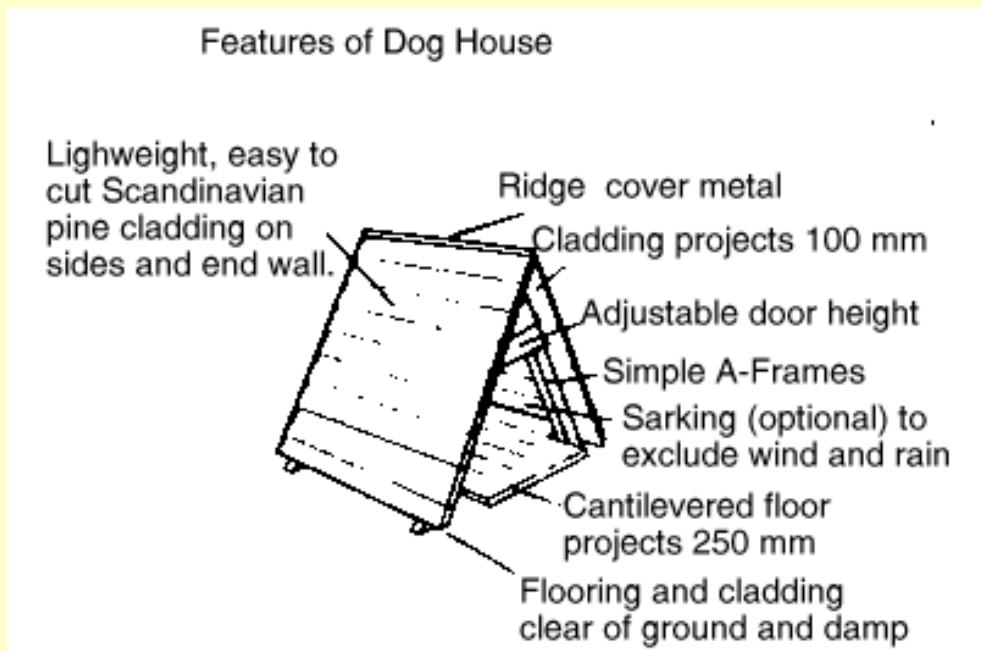

CUT A-FRAME PIECES

From the 1.2m lengths of 75 x 50mm timber, cut **four** A-Frame legs (A) to this pattern using the 60o/30o set square to mark the angles shown.

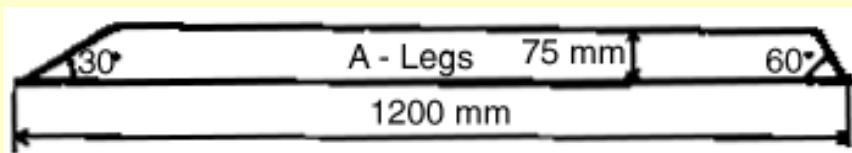

CUT FLOOR PLATE

From the remaining two lengths of 75 x 50mm pieces, cut two floor plates (B) to pattern below, using the 60o/30o set square to mark the angles shown.

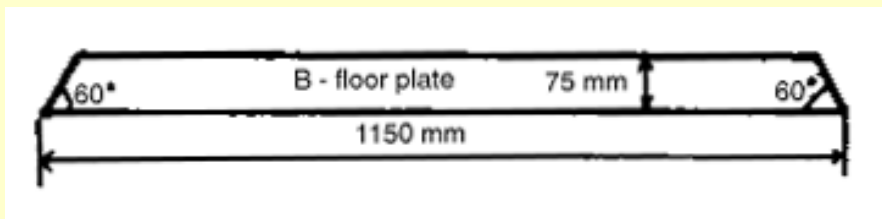

CUT TWO GUSSET PLATES

From a piece of Scandinavian Pine or other flat sheet material cut two gusset plates (C) to the pattern below using the 60o/30o set square to mark the angles shown.

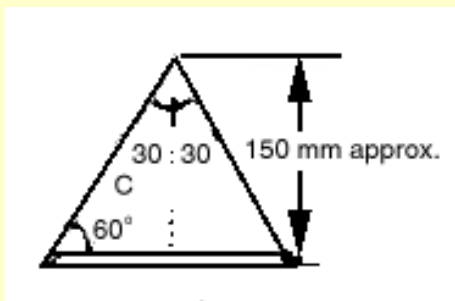

ASSEMBLE A-FRAMES

Using two of the legs (A) cut in (1), and a floor (B) as in (2) and gusset plates (C), assemble and fix components to make two A-Frames as in sketch below.

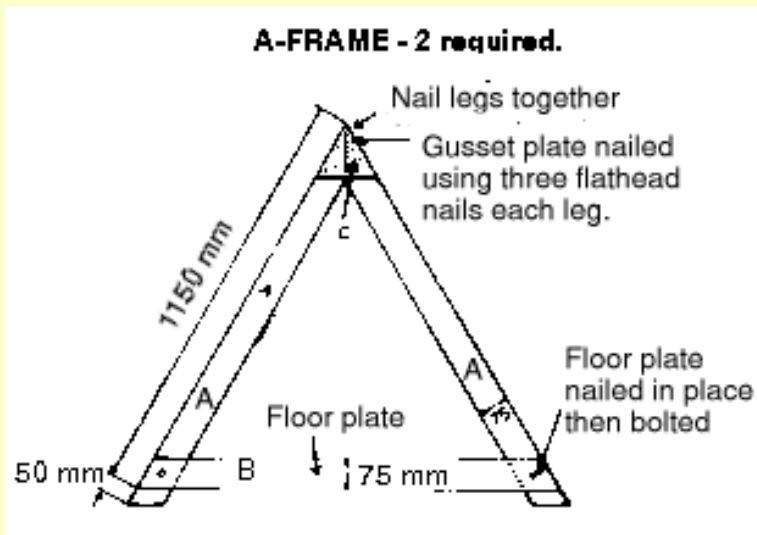

CUT FLOORING

From the flooring material cut two short boards for side pieces each 900mm long. Cut two boards approx. 950mm cut remaining floor boards to 1200mm length sufficient to cover the floor plate, allowing boards to be fixed closely together.

FIX FLOORING

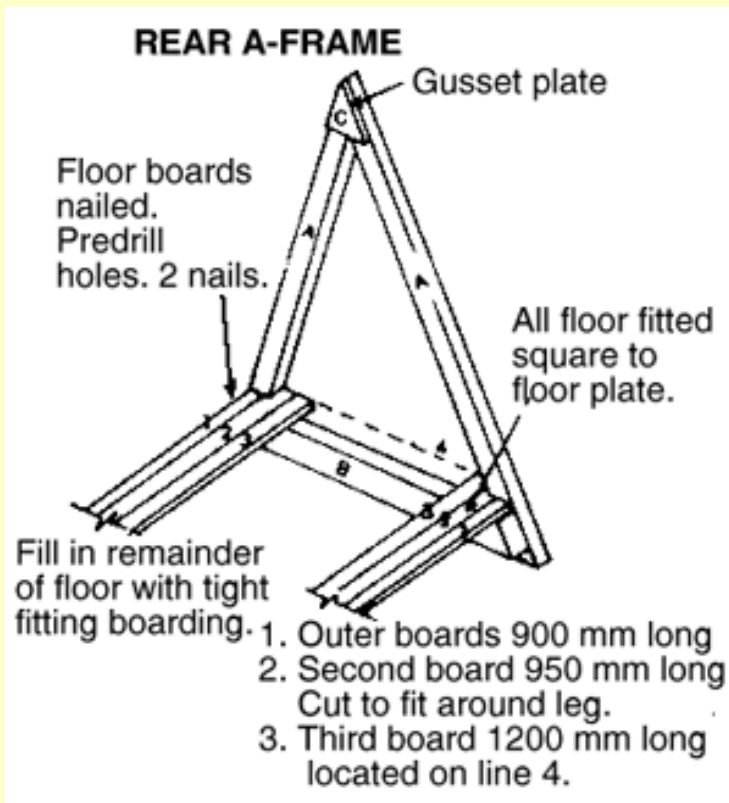

(a) Select one of the assembled A-Frames and fix flooring square to floor as shown in plan diagram using two nails at each board - pre-drilling nail holes at end of board.

FIX FLOORING

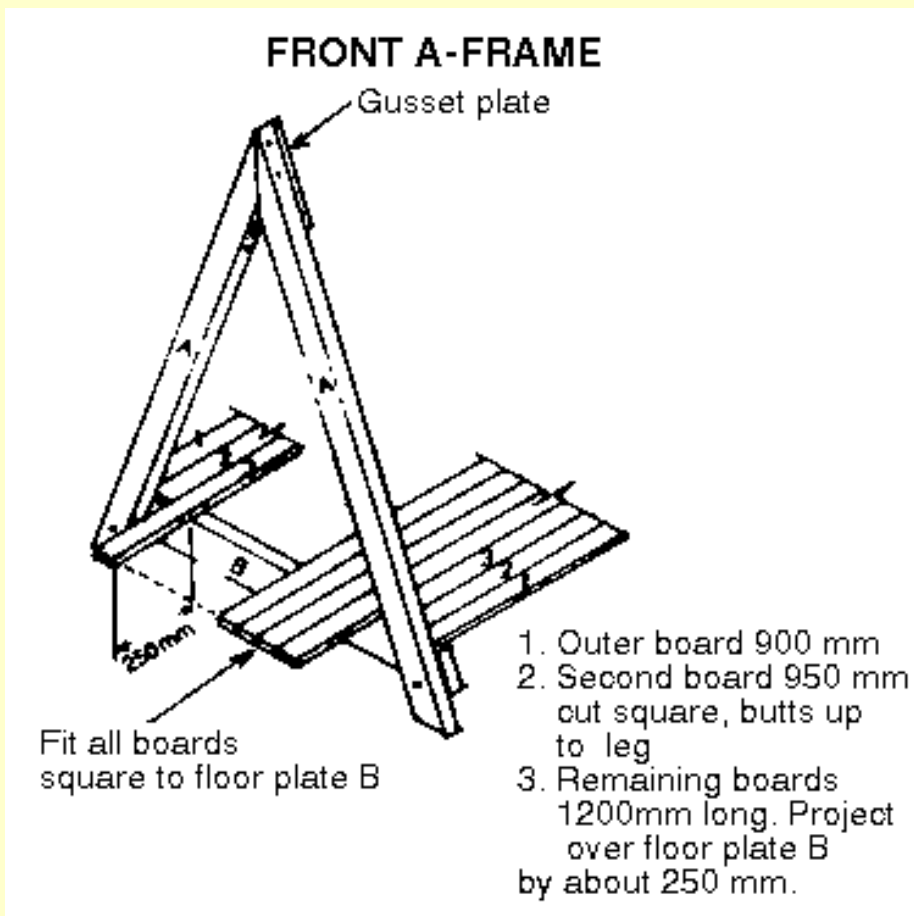

(b) To the remaining A-Frame fix the floor boards to the floor plate as shown in diagram, similarly pre-drilling nail holes at end of boards.

CUT AND FIX SIDE CLADDING

(I) Cut lengths of cladding to 1200mm lengths. Commencing with top of (A) temporarily fix one board square to (A) legs allowing projection of approx. 100mm both front and back beyond A-Frame. Use two nails on each end of the cladding piece (Note: spacing at top between frames should be exactly the same as that at flooring level i.e. 900mm).

Sarking of building paper/heavy polythene is suggested. Fix this to open side by stapling or light tacking with cut tacks or similar. Then permanently fix a top cladding piece to this covered side, using two nails each leg. To complete this sarked side, continue fixing cladding sufficient to cover exposed ends of floor plates (B).

Remove temporary top cladding piece and fix sarking to second side. Fix cladding to second side, as in (II) above.

(Note: Allow sarking to slightly sag between frames and extend well over the edges of the outer floor boards).

CUT AND FIX END CLADDING

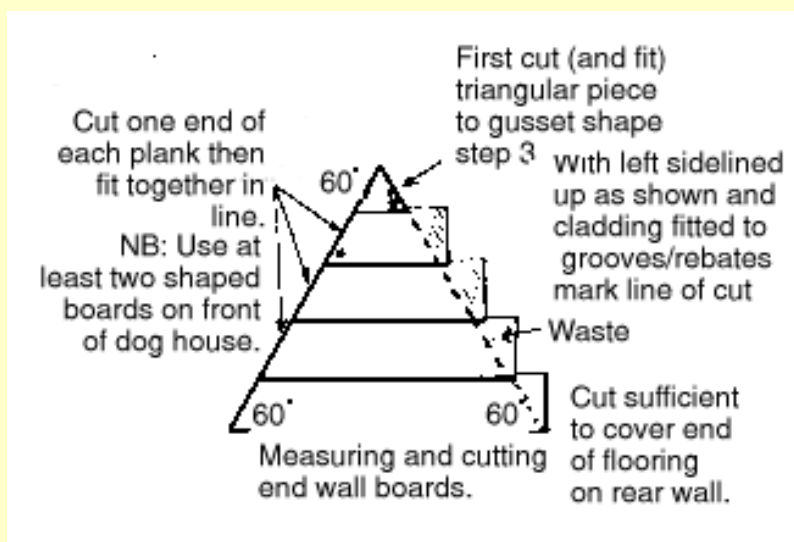

Cut first piece of end cladding to shape given for gusset plate (Step 3). Then continue cutting cladding pieces as required in diagram (See Step 10).

FIX FRONT CLADDING

Fix at least two pieces of angle cut cladding to front of structure. This could be increased so as to reduce height of door, depending on size of dog.

FIX REAR CLADDING

Loosely fix shaped piece of selected sarking to outside end frame, so as to drape outside edges of flooring. Commencing with topmost piece, cut and nail fix sufficient cladding to cover exposed ends of decking floor. Allow clearance between end cladding and ground line of at least 50mm.

CUT OFF, SAND OR SMOOTH

Cut off, sand or smooth to common line the exposed ends of cladding, similarly round off and smooth projecting floor boards.

PRIME COAT DOG KENNEL

Apply recommended prime coat(s) of selected coating system to exposed timbers including under flooring.

CUT AND FIX RIDGE CAPPING

Cut 1200mm length of selected ridge capping. Fix to ridge using zinc plated, round head, self tapping metal thread screws in pre-drilled holes. Prime coat ridge capping.

COMPLETE PAINTING

Apply final coats of selected paint/stain finish and allow several days to thoroughly dry and all odours to evaporate before introducing dog to new residence.

LOCATING DOG KENNEL

Locate dog kennel so that the doorway is protected from the worst of the rainy/windy weather. Place legs so that the floor would slightly slope own towards the doorway. We suggest you put legs on bricks rather than on grass or soil.

OTHER SIZE DOG KENNELS

The size of the dog kennel can be increased to fit your dog by using longer legs to the A-Frame and longer floor plates. However retain the angles of 60o/30o where indicated on frames and on the end cladding.

[Tips Index](#)

[Timber Talk with Harry & Sal](#)

Disclaimer: While the Timber and Building Materials Association (NSW) Limited (TABMA) and its members believe this publication is an invaluable guide to this project, the Association cannot guarantee that every statement is without flaw. Therefore, the Association and its members hereby disclaim all liability for error or omissions of any kind, whether they be negligent or otherwise, or for any loss, damage or other consequence which may arise from any person relying on information stated in this publication.

This document was prepared with the assistance and co-operation of the Timber Development Association NSW Ltd.

For further advice telephone the TDA Timber Industry Advisory Service on (02) 360 3088.

Copyright Owner: Timber and Building Materials Association (NSW) Limited.



AUSTRALIA'S
National Association of **Forest Industries**

Timber Tips